



Aluminum electrolytic capacitors

Snap-in capacitors

Series/Type: B43504
Date: July 2007

Long-life grade capacitors

Applications

- Frequency converters
- Professional power supplies in industrial electronics and in data processing equipment
- Switch-mode power supplies in entertainment electronics

Features

- High reliability
- High CV product, compact
- High ripple current capability
- Low ESR
- Different case sizes available for each capacitance value

Construction

- Charge/discharge-proof, polar
- Aluminum case, fully insulated
- Snap-in solder pins to hold component in place on PC-board
- Minus pole marking on case surface
- Minus pole not insulated from case
- Overload protection by safety vent on the base

Terminals

- Standard version with 2 terminals,
2 lengths available: 6.3 and 4.5 mm
- 3 terminals to ensure correct insertion: length 4.5 mm

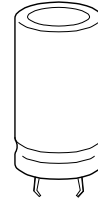

Specifications and characteristics in brief

Rated voltage V_R	200 ... 450 V DC	
Surge voltage V_S	1.15 · V_R (for $V_R \leq 250$ V DC) 1.10 · V_R (for $V_R \geq 400$ V DC)	
Rated capacitance C_R	47 ... 2200 μ F	
Capacitance tolerance	$\pm 20\% \triangleq M$	
Dissipation factor $\tan \delta$ (20 °C, 120 Hz)	$V_R \leq 400$ V DC: $\tan \delta \leq 0.15$ $V_R \geq 420$ V DC: $\tan \delta \leq 0.20$	
Leakage current I_{leak} (5 min, 20 °C)	$I_{leak} \leq 0.3 \mu A \cdot \left(\frac{C_R}{\mu F} \cdot \frac{V_R}{V} \right)^{0.7} + 4 \mu A$	
Self-inductance ESL	Approx. 20 nH	
Useful life		Requirements:
105 °C, V_R , $I_{AC,R}$	> 3000 h	$\Delta C/C \leq \pm 30\%$ of initial value
85 °C, V_R , $I_{AC,max}$	> 6500 h	$\tan \delta \leq 3$ times initial specified limit
40 °C, V_R , $1.9 \cdot I_{AC,R}$	> 200000 h	$I_{leak} \leq$ initial specified limit
Load life test		Post test requirements
105 °C, V_R , $I_{AC,R}$	2000 h	$\Delta C/C \leq \pm 20\%$ of initial value
		$\tan \delta \leq 2$ times initial specified limit
		$I_{leak} \leq$ initial specified limit
Voltage endurance test		Post test requirements:
105 °C, V_R	2000 h	$\Delta C/C \leq \pm 10\%$ of initial value
		$\tan \delta \leq 1.3$ times initial specified limit
		$I_{leak} \leq$ initial specified limit
Vibration resistance test	To IEC 60068-2-6, test Fc: Displacement amplitude 0.35 mm, frequency range 10 Hz ... 55 Hz, acceleration max. 5 g, duration 3 × 2 h. Capacitor mounted by its body which is rigidly clamped to the work surface.	
Characteristics at low temperature	Impedance ratio: $\frac{Z_{-40^\circ C}}{Z_{+20^\circ C}} (100\text{Hz}) \leq 7$ (at $V_R \leq 400$ V DC) ≤ 15 (at $V_R \geq 420$ V DC)	
IEC climatic category	To IEC 60068-1: $V_R \leq 400$ V DC: 40/105/56 (–40 °C/+105 °C/56 days damp heat test) $V_R \geq 420$ V DC: 25/105/56 (–25 °C/+105 °C/56 days damp heat test)	
Detail specification	Similar to CECC 30301-809	
Sectional specification	IEC 60384-4	



B43504

Compact – 105 °C

Dimensional drawings

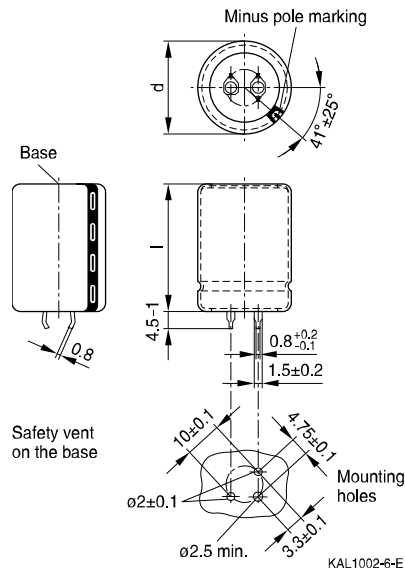
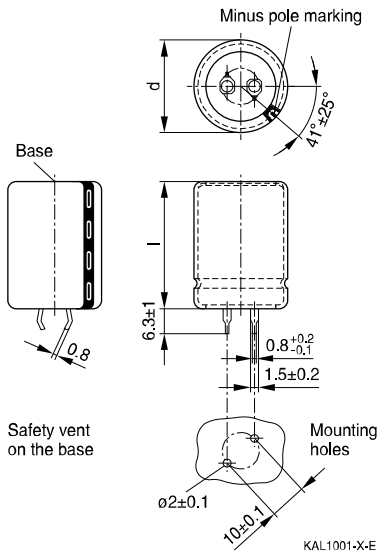

Snap-in terminals, length 6.3 ± 1 mm.
Also available in a shorter version with a length of $4.5 - 1$ mm. For packing mode and ordering example see next page.

Snap-in capacitors are also available with 3 terminals (length $4.5 - 1$ mm).
For packing mode and ordering example see next page.

Dimensions (mm)		Approx weight(g)	Packing units (pcs.)
d +1	l ±2		
22	25	9	160
22	30	12	160
22	35	15	160
22	40	18	160
22	45	20	160
<hr/>			
25	25	13	130
25	30	17	130
25	35	19	130
25	40	22	130
25	45	25	130
25	50	29	130
25	55	32	130

Dimensions (mm)		Approx weight(g)	Packing units (pcs.)
d +1	l ±2		
30	25	17	80
30	30	23	80
30	35	29	80
30	40	36	80
30	45	41	80
30	50	46	80
30	55	53	80
<hr/>			
35	25	22	60
35	30	29	60
35	35	36	60
35	40	41	60
35	45	56	60
35	50	70	60
35	55	81	60



Packing of snap-in capacitors



For ecological reasons the packing is pure cardboard. Components can be withdrawn (in full or in part) in the correct position for insertion.

Ordering codes for terminal styles

Snap-in capacitors Terminal versions	Identification in 3rd block of ordering code
Standard terminals (6.3 ±1) mm	M000
Short terminals (4.5 –1) mm	M007
3 terminals (4.5 –1) mm	M002

Ordering examples:

- B43504A9107M007 } snap-in capacitor with short terminals
- B43504A9107M002 } snap-in capacitor with 3 terminals



B43504

Compact – 105 °C

Overview of available types

V _R (V DC)	200	250	400	420	450
	Case dimensions d × l (mm)				
C _R (μF)					
47			22 × 25		
68			22 × 25		22 × 30
82			22 × 30	22 × 30	22 × 35
100			22 × 35 25 × 25	22 × 35 25 × 30	22 × 35 25 × 30 30 × 25
120			22 × 35	22 × 40 25 × 30	25 × 35
150			22 × 40 30 × 25	25 × 35 30 × 30	25 × 40 30 × 30 35 × 25
180			25 × 40 30 × 30	25 × 40 30 × 30	25 × 45
220	22 × 25	22 × 30	25 × 45 30 × 35 35 × 25	25 × 45 30 × 35	25 × 50 30 × 40 35 × 30
270	22 × 25	22 × 30	25 × 50 30 × 40 35 × 30	25 × 55 30 × 40	30 × 45 35 × 35
330	22 × 30	22 × 35 25 × 30	25 × 55 30 × 45 35 × 35	30 × 45 35 × 35	30 × 50 35 × 40
390	22 × 30	25 × 35	30 × 50 35 × 40	30 × 50 35 × 40	35 × 45
470	22 × 35 25 × 30 30 × 25	22 × 45 30 × 30	30 × 55 35 × 45	35 × 45	35 × 50
560	25 × 35	25 × 40	35 × 50	35 × 50	
680	25 × 40 30 × 30 35 × 25	25 × 50 30 × 35 35 × 30	35 × 55		
820	25 × 45 35 × 30	25 × 55 30 × 40			



B43504

Compact – 105 °C



V _R (V DC)	200	250	400	420	450
	Case dimensions d × l (mm)				
C _R (μF)					
1000	25 × 50 30 × 35 35 × 30	30 × 45 35 × 40			
1200	30 × 40	30 × 55 35 × 40			
1500	30 × 50 35 × 40	35 × 50			
1800	35 × 45	35 × 55			
2200	35 × 50				

The capacitance and voltage ratings listed above are available in different cases upon request. Other voltage and capacitance ratings are also available upon request.

B43504
Compact – 105 °C
Technical data and ordering codes

C _R 100 Hz 20 °C μF	Case dimensions d × l mm	ESR _{typ} 100 Hz 20 °C mΩ	Z _{max} 10 kHz 20 °C mΩ	I _{AC,max} 100 Hz 60 °C A	I _{AC,max} 100 Hz 85 °C A	I _{AC,R} ¹⁾ 100 Hz 105 °C A	Ordering code (composition see below)
V_R = 200 V DC							
220	22 × 25	580	700	2.26	1.70	0.84	B43504E2227M00*
270	22 × 25	470	570	2.51	1.90	0.93	B43504E2277M00*
330	22 × 30	390	470	2.97	2.22	1.10	B43504A2337M00*
390	22 × 30	330	400	3.24	2.42	1.20	B43504E2397M00*
470	22 × 35	270	330	3.78	2.83	1.40	B43504E2477M00*
470	25 × 30	270	330	3.80	2.86	1.41	B43504G2477M00*
470	30 × 25	270	330	4.05	3.03	1.50	B43504F2477M00*
560	25 × 35	230	280	4.40	3.40	1.63	B43504E2567M00*
680	25 × 40	190	230	5.13	3.90	1.90	B43504E2687M00*
680	30 × 30	190	230	5.02	3.76	1.86	B43504H2687M00*
680	35 × 25	190	230	5.40	4.04	2.00	B43504F2687M00*
820	25 × 45	160	190	5.94	4.50	2.20	B43504E2827M00*
820	35 × 30	160	190	6.21	4.70	2.30	B43504A2827M00*
1000	25 × 50	140	180	6.75	5.06	2.50	B43504G2108M00*
1000	30 × 35	140	180	6.48	4.90	2.40	B43504H2108M00*
1000	35 × 30	140	180	6.77	5.07	2.51	B43504J2108M00*
1200	30 × 40	120	150	7.37	5.60	2.73	B43504F2128M00*
1500	30 × 50	100	120	8.96	6.72	3.32	B43504F2158M00*
1500	35 × 40	100	120	9.18	6.90	3.40	B43504G2158M00*
1800	35 × 45	80	100	10.5	7.90	3.90	B43504F2188M00*
2200	35 × 50	65	80	11.9	9.10	4.43	B43504F2228M00*
V_R = 250 V DC							
220	22 × 30	580	700	2.40	1.80	0.89	B43504A2227M00*
270	22 × 30	470	570	2.67	2.00	0.99	B43504B2277M00*
330	22 × 35	390	470	3.10	2.34	1.15	B43504D2337M00*
330	25 × 30	390	470	3.24	2.42	1.20	B43504C2337M00*
390	25 × 35	330	400	3.78	2.83	1.40	B43504A2397M00*
470	22 × 45	270	330	4.10	3.08	1.52	B43504C2477M00*
470	30 × 30	270	330	4.32	3.23	1.60	B43504B2477M00*
560	25 × 40	230	280	4.64	3.47	1.72	B43504B2567M00*
680	25 × 50	190	230	5.67	4.24	2.10	B43504A2687M00*

Composition of ordering code

* = Terminal style

0 = snap-in standard terminals (6.3 ± 1) mm

2 = snap-in 3 terminals (4.5 – 1) mm

7 = snap-in short terminals (4.5 – 1) mm

 1) 120-Hz conversion factor of ripple current: I_{AC} (120 Hz) = 1.03 · I_{AC} (100 Hz)



B43504

Compact – 105 °C



Technical data and ordering codes

C _R 100 Hz 20 °C μF	Case dimensions d × l mm	ESR _{typ} 100 Hz 20 °C mΩ	Z _{max} 10 kHz 20 °C mΩ	I _{AC,max} 100 Hz 60 °C A	I _{AC,max} 100 Hz 85 °C A	I _{AC,R} ²⁾ 100 Hz 105 °C A	Ordering code (composition see below)
V_R = 250 V DC							
680	30 × 35	190	230	5.29	3.97	1.96	B43504C2687M00*
680	35 × 30	190	230	5.56	4.18	2.06	B43504D2687M00*
820	25 × 55	160	190	6.37	4.76	2.36	B43504C2827M00*
820	30 × 40	160	190	6.10	4.57	2.26	B43504D2827M00*
1000	30 × 45	140	180	7.04	5.27	2.61	B43504B2108M00*
1000	35 × 40	140	180	7.56	5.70	2.80	B43504C2108M00*
1200	30 × 55	120	150	8.34	6.24	3.09	B43504B2128M00*
1200	35 × 40	120	150	8.15	6.11	3.02	B43504C2128M00*
1500	35 × 50	100	120	9.88	7.40	3.66	B43504A2158M00*
1800	35 × 55	80	100	11.2	8.40	4.16	B43504A2188M00*
V_R = 400 V DC							
47	22 × 25	1860	2310	1.05	0.79	0.39	B43504A9476M00*
68	22 × 25	1290	1600	1.26	0.95	0.47	B43504A9686M00*
82	22 × 30	1070	1320	1.48	1.11	0.55	B43504A9826M00*
100	22 × 35	880	1090	1.72	1.36	0.64	B43504A9107M00*
100	25 × 25	880	1090	1.64	1.30	0.61	B43504B9107M00*
120	22 × 35	730	910	1.89	1.41	0.70	B43504A9127M00*
150	22 × 40	580	730	2.21	1.70	0.82	B43504A9157M00*
150	30 × 25	580	730	2.21	1.70	0.82	B43504B9157M00*
180	25 × 40	490	610	2.64	2.04	0.98	B43504A9187M00*
180	30 × 30	490	610	2.59	2.00	0.96	B43504B9187M00*
220	25 × 45	400	500	3.02	2.32	1.12	B43504A9227M00*
220	30 × 35	400	500	2.99	2.30	1.11	B43504B9227M00*
220	35 × 25	400	500	2.99	2.30	1.11	B43504D9227M00*
270	25 × 50	320	410	3.51	2.70	1.30	B43504A9277M00*
270	30 × 40	320	410	3.48	2.68	1.29	B43504B9277M00*
270	35 × 30	320	410	3.51	2.70	1.30	B43504C9277M00*
330	25 × 55	270	330	4.02	3.08	1.49	B43504C9337M00*
330	30 × 45	270	330	4.05	3.10	1.50	B43504A9337M00*
330	35 × 35	270	330	4.07	3.12	1.51	B43504B9337M00*
390	30 × 50	220	280	4.59	3.50	1.70	B43504A9397M00*

Composition of ordering code

* = Terminal style

0 = snap-in standard terminals (6.3 ± 1) mm

2 = snap-in 3 terminals (4.5 – 1) mm

7 = snap-in short terminals (4.5 – 1) mm

2) 120-Hz conversion factor of ripple current: I_{AC} (120 Hz) = 1.03 · I_{AC} (100 Hz)



B43504

Compact – 105 °C

Technical data and ordering codes

C _R 100 Hz 20 °C μF	Case dimensions d × l mm	ESR _{typ} 100 Hz 20 °C mΩ	Z _{max} 10 kHz 20 °C mΩ	I _{AC,max} 100 Hz 60 °C A	I _{AC,max} 100 Hz 85 °C A	I _{AC,R} ³⁾ 100 Hz 105 °C A	Ordering code (composition see below)
V_R = 400 V DC							
390	35 × 40	220	280	4.64	3.54	1.72	B43504B9397M00*
470	30 × 55	190	240	5.21	3.90	1.93	B43504B9477M00*
470	35 × 45	190	240	5.40	4.10	2.00	B43504A9477M00*
560	35 × 50	160	200	6.02	4.60	2.23	B43504A9567M00*
680	35 × 55	130	160	6.88	5.16	2.55	B43504A9687M00*
V_R = 420 V DC							
82	22 × 30	1650	1950	1.48	1.12	0.55	B43504A0826M00*
100	22 × 35	1350	1600	1.72	1.31	0.64	B43504A0107M00*
100	25 × 30	1350	1600	1.75	1.34	0.65	B43504E0107M00*
120	22 × 40	1130	1330	1.99	1.51	0.74	B43504A0127M00*
120	25 × 30	1130	1330	1.94	1.47	0.72	B43504E0127M00*
150	25 × 35	900	1070	2.29	1.74	0.85	B43504A0157M00*
150	30 × 30	900	1070	2.37	1.80	0.88	B43504E0157M00*
180	25 × 40	750	890	2.64	2.00	0.98	B43504A0187M00*
180	30 × 30	750	890	2.59	1.97	0.96	B43504E0187M00*
220	25 × 45	610	730	3.05	2.31	1.13	B43504A0227M00*
220	30 × 35	610	730	3.02	2.29	1.12	B43504E0227M00*
270	25 × 55	500	590	3.64	2.73	1.35	B43504B0277M00*
270	30 × 40	500	590	3.51	2.66	1.30	B43504A0277M00*
330	30 × 45	410	490	4.05	3.08	1.50	B43504A0337M00*
330	35 × 35	410	490	4.10	3.11	1.52	B43504E0337M00*
390	30 × 50	350	410	4.59	3.48	1.70	B43504A0397M00*
390	35 × 40	350	410	4.64	3.54	1.72	B43504E0397M00*
470	35 × 45	290	340	5.31	4.05	1.97	B43504A0477M00*
560	35 × 50	240	290	6.02	4.52	2.23	B43504A0567M00*
V_R = 450 V DC							
68	22 × 30	1990	2350	1.35	1.01	0.50	B43504A5686M00*
82	22 × 35	1650	1950	1.56	1.20	0.58	B43504A5826M00*
100	22 × 35	1350	1600	1.72	1.30	0.64	B43504A5107M00*
100	25 × 30	1350	1600	1.75	1.31	0.65	B43504B5107M00*
100	30 × 25	1350	1600	1.80	1.40	0.67	B43504C5107M00*

Composition of ordering code

* = Terminal style

- 0 = snap-in standard terminals (6.3 ±1) mm
- 2 = snap-in 3 terminals (4.5 –1) mm
- 7 = snap-in short terminals (4.5 –1) mm

3) 120-Hz conversion factor of ripple current: I_{AC} (120 Hz) = 1.03 · I_{AC} (100 Hz)



B43504

Compact – 105 °C



Technical data and ordering codes

C _R	Case dimensions	ESR _{typ}	Z _{max}	I _{AC,max}	I _{AC,max}	I _{AC,R} ⁴⁾	Ordering code (composition see below)
100 Hz	d × l	100 Hz	10 kHz	100 Hz	100 Hz	100 Hz	
20 °C	mm	20 °C	20 °C	60 °C	85 °C	105 °C	
μF		mΩ	mΩ	A	A	A	
V_R = 450 V DC							
120	25 × 35	1130	1330	2.05	1.60	0.76	B43504A5127M00*
150	25 × 40	900	1070	2.40	1.82	0.89	B43504A5157M00*
150	30 × 30	900	1070	2.37	1.80	0.88	B43504B5157M00*
150	35 × 25	900	1070	2.48	1.90	0.92	B43504C5157M00*
180	25 × 45	750	890	2.75	2.10	1.02	B43504A5187M00*
220	25 × 50	610	730	3.24	2.42	1.20	B43504A5227M00*
220	30 × 40	610	730	3.24	2.42	1.20	B43504B5227M00*
220	35 × 30	610	730	3.24	2.42	1.20	B43504C5227M00*
270	30 × 45	500	590	3.78	2.83	1.40	B43504A5277M00*
270	35 × 35	500	590	3.78	2.83	1.40	B43504B5277M00*
330	30 × 50	410	490	4.32	3.30	1.60	B43504A5337M00*
330	35 × 40	410	490	4.32	3.30	1.60	B43504B5337M00*
390	35 × 45	350	410	4.86	3.70	1.80	B43504A5397M00*
470	35 × 50	290	340	5.67	4.24	2.10	B43504A5477M00*

Composition of ordering code

- * = Terminal style
- 0 = snap-in standard terminals (6.3 ±1) mm
- 2 = snap-in 3 terminals (4.5 –1) mm
- 7 = snap-in short terminals (4.5 –1) mm

4) 120-Hz conversion factor of ripple current: I_{AC} (120 Hz) = 1.03 · I_{AC} (100 Hz)



B43504
Compact – 105 °C

Useful life

depending on ambient temperature T_A under ripple current operating conditions¹⁾

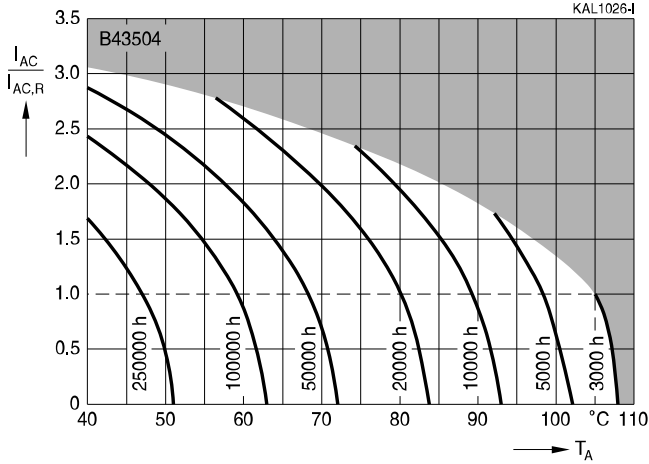

Frequency factor of permissible ripple current I_{AC} versus frequency f

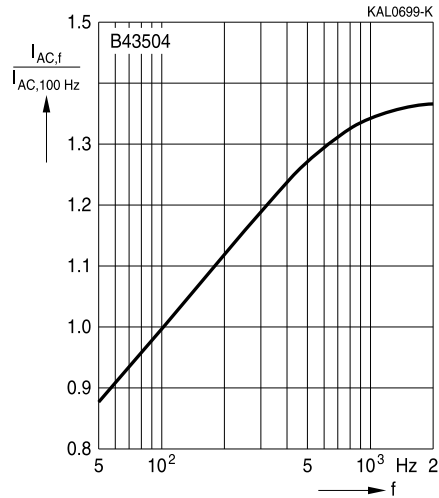

Frequency characteristics of ESR
 Typical behavior

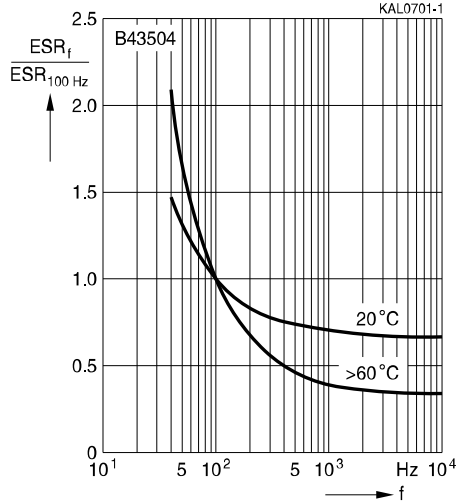

1) Refer to chapter "General technical information, 5.3 Calculation of useful life" for an explanation on how to interpret the useful life graphs.



Impedance Z versus frequency f

Typical behavior at 20 °C

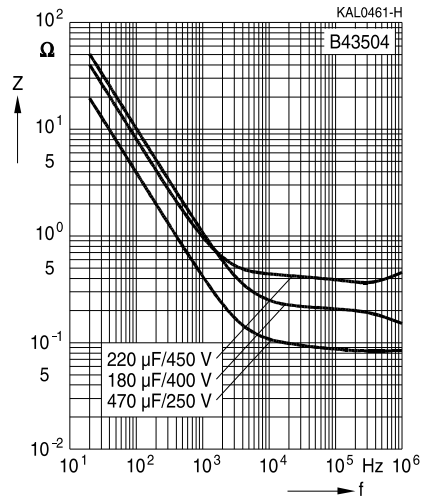



B43504

Compact – 105 °C

Cautions and warnings

Personal safety

The electrolytes used by EPCOS have not only been optimized with a view to the intended application, but also with regard to health and environmental compatibility. They do not contain any solvents that are detrimental to health, e.g. dimethyl formamide (DMF) or dimethyl acetamide (DMAC).

Furthermore, part of the high-voltage electrolytes used by EPCOS are self-extinguishing. They contain flame-retarding substances which will quickly extinguish any flame that may have been ignited.

As far as possible, EPCOS does not use any dangerous chemicals or compounds to produce operating electrolytes. However, in exceptional cases, such materials must be used in order to achieve specific physical and electrical properties because no safe substitute materials are currently known. However, the amount of dangerous materials used in our products has been limited to an absolute minimum. Nevertheless, the following rules should be observed when handling Al electrolytic capacitors:

- Any escaping electrolyte should not come into contact with eyes or skin.
- If electrolyte does come into contact with the skin, wash the affected parts immediately with running water. If the eyes are affected, rinse them for 10 minutes with plenty of water. If symptoms persist, seek medical treatment.
- Avoid breathing in electrolyte vapor or mists. Workplaces and other affected areas should be well ventilated. Clothing that has been contaminated by electrolyte must be changed and rinsed in water.



Product safety

The table below summarize the safety instructions that must be observed without fail. A detailed description can be found in the relevant sections of chapter "General technical information".

Topic	Safety information	Reference Chapter "General technical information"
Polarity	Make sure that polar capacitors are connected with the right polarity.	1 "Basic construction of aluminum electrolytic capacitors"
Reverse voltage	Voltages polarity classes should be prevented by connecting a diode.	3.1.6 "Reverse voltage"
Upper category temperature	Do not exceed the upper category temperatur.	7.2 "Maximum permissible operating temperature"
Maintenance	Make periodic inspections of the capacitors. Before the inspection, make sure that the power supply is turned off and carefully discharge the electricity of the capacitors. Do not apply any mechanical stress to the capacitor terminals.	10 "Maintenance"
Mounting position of screw terminal capacitors	Do not mount the capacitor with the terminals (safety vent) upside down.	11.1. "Mounting positions of capacitors with screw terminals"
Mounting of single-ended capacitors	The internal structure of single-ended capacitors might be damaged if excessive force is applied to the lead wires. Avoid any compressive, tensile or flexural stress. Do not move the capacitor after soldering to PC board. Do not pick up the PC board by the soldered capacitor. Do not insert the capacitor on the PC board with a hole space different to the lead space specified.	11.4 "Mounting considerations for single-ended capacitors"
Robustness of terminals	The following maximum tightening torques must not be exceeded when connecting screw terminals: M5: 2 Nm M6: 2.5 Nm	11.3 "Mounting torques"
Soldering	Do not exceed the specified time or temperature limits during soldering.	11.5 "Soldering"



B43504

Compact – 105 °C

Topic	Safety information	Reference Chapter "General technical information"
Soldering, cleaning agents	Do not allow halogenated hydrocarbons to come into contact with aluminum electrolytic capacitors.	11.6 "Cleaning agents"
Passive flammability	Avoid external energy, such as fire or electricity.	8.1 "Passive flammability"
Active flammability	Avoid overload of the capacitors.	8.2 "Active flammability"
		Reference Chapter "Capacitors with screw terminals"
Breakdown strength of insulating sleeves	Do not damage the insulating sleeve, especially when ring clips are used for mounting.	"Screw terminals - accessories"



Important notes

The following applies to all products named in this publication:

1. Some parts of this publication contain **statements about the suitability of our products for certain areas of application**. These statements are based on our knowledge of typical requirements that are often placed on our products in the areas of application concerned. We nevertheless expressly point out **that such statements cannot be regarded as binding statements about the suitability of our products for a particular customer application**. As a rule, EPCOS is either unfamiliar with individual customer applications or less familiar with them than the customers themselves. For these reasons, it is always ultimately incumbent on the customer to check and decide whether an EPCOS product with the properties described in the product specification is suitable for use in a particular customer application.
2. We also point out that **in individual cases, a malfunction of passive electronic components or failure before the end of their usual service life cannot be completely ruled out in the current state of the art, even if they are operated as specified**. In customer applications requiring a very high level of operational safety and especially in customer applications in which the malfunction or failure of a passive electronic component could endanger human life or health (e.g. in accident prevention or life-saving systems), it must therefore be ensured by means of suitable design of the customer application or other action taken by the customer (e.g. installation of protective circuitry or redundancy) that no injury or damage is sustained by third parties in the event of malfunction or failure of a passive electronic component.
3. **The warnings, cautions and product-specific notes must be observed.**
4. In order to satisfy certain technical requirements, **some of the products described in this publication may contain substances subject to restrictions in certain jurisdictions (e.g. because they are classed as "hazardous")**. Useful information on this will be found in our Material Data Sheets on the Internet (www.epcos.com/material). Should you have any more detailed questions, please contact our sales offices.
5. We constantly strive to improve our products. Consequently, **the products described in this publication may change from time to time**. The same is true of the corresponding product specifications. Please check therefore to what extent product descriptions and specifications contained in this publication are still applicable before or when you place an order. We also **reserve the right to discontinue production and delivery of products**. Consequently, we cannot guarantee that all products named in this publication will always be available.
6. Unless otherwise agreed in individual contracts, **all orders are subject to the current version of the "General Terms of Delivery for Products and Services in the Electrical Industry" published by the German Electrical and Electronics Industry Association (ZVEI)**.
7. The trade names EPCOS, BAOKE, Alu-X, CeraDiode, CSSP, MiniBlue, MKK, MLSC, MotorCap, PCC, PhaseCap, PhaseMod, SIFERRIT, SIFI, SIKOREL, SilverCap, SIMDAD, SIMID, SineFormer, SIOV, SIP5D, SIP5K, ThermoFuse, WindCap are **trademarks registered or pending** in Europe and in other countries. Further information will be found on the Internet at www.epcos.com/trademarks.